

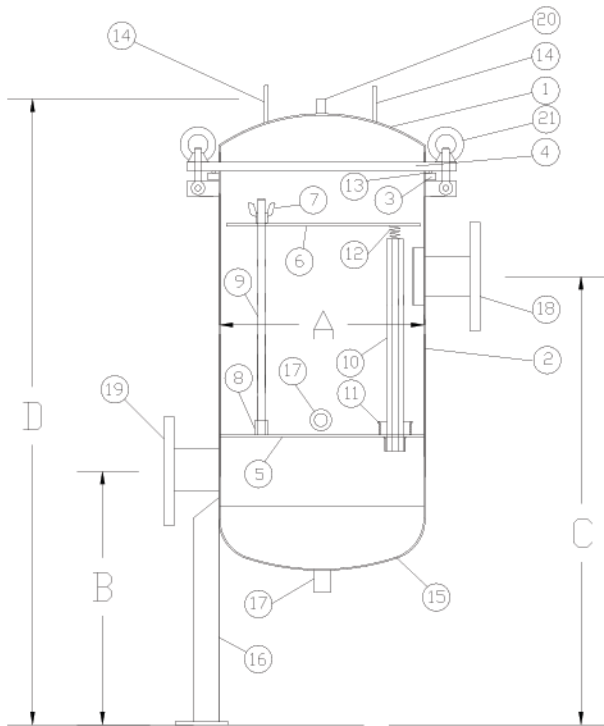

SPECIFICATION

Material	: 304 SS, 316L SS
Finishing	: Mirror Polish, Sand Blast
Inlet / Outlet	: 2" NPT (F), 2" Flange
Vent	: 1/4" NPT (F)
Drain	: 1/2" NPT (F)

MODEL	CARTRIDGES	Dimension (mm)			
		A	B	C	D
CFH 7 - SB	7 ROUND 10"	250	260	380	694
CFH 14 - SB	7 ROUND 20"	250	260	390	934
CFH 21 - SB	7 ROUND 30"	250	260	490	1324
CFH 28 - SB	7 ROUND 40"	250	260	520	1544



Design pressure : 185 psi
 Max. Operating pressure : 150 psi
 Design temperature : 50 to 200 Degree Celcius

PARTS LIST

No	Description	Qty.
1	Top Lid	1
2	Body	1
3	O-ring Brim	1
4	Top Lid Brim	1
5	Cartridge Support Plate	1
6	Press Plate	1
7	Press Nut	3
8	Fixed nut	3
9	Thread Rod	3
10	Cartridge position bar	7
11	Cartridge position cup	7
12	Press spring	7
13	O-ring	1
14	Handle	2
15	Bottom Lid	1
16	Leg	4
17	Drain	2
18	Intlet	1
19	Outlet	1
20	Vent	1
21	Swing Bolt & Nut	4